

# MotorGuide® REPAIR PARTS

**Model:**  
**580V**

**SPECIFICATIONS:**

Year of Intro	2000
Thrust	80 LBS
Volts	24VDC
Amp Draw	0 to 33amps
Mount	20 Bow
Speeds	Variable

**PARTS ORDERING & TECH ASSISTANCE**

MotorGuide Consumer Relations  
Phone 918-831-6989  
Fax 800-982-8093

*Returned Goods must be accompanied with a Returned Goods Authorization. Contact MotorGuide Consumer Relations to obtain RGA.*

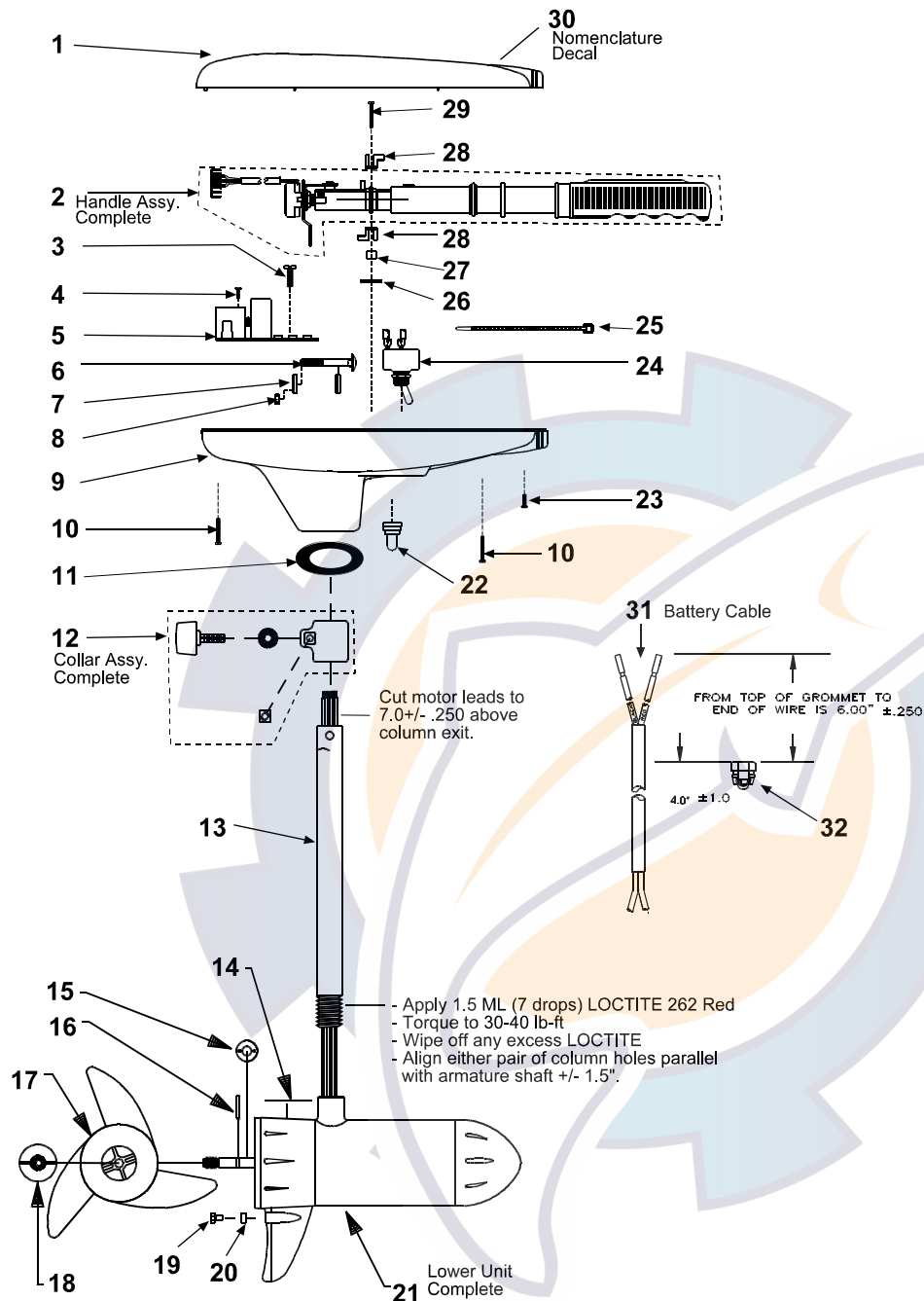

KEY	DESCRIPTION	PART #	KEY	DESCRIPTION	PART #
1	TOP HOUSING COVER BLACK	AT053-10	19	N/A	
2	HANDLE ASY	AT372-05	20	N/A	
3	#10 X 1/2" SCREW	RT133-03	21	MOTOR	TF397-01
4	#4 SELF TAPPING SCREW	AF141-01	22	SWITCH BOOT	FP177-01
5	BOARD FOR/REV	AT157-02	23	SCREW #8X1/2"	FR135-01
6	BOLT	TT134-02	24	TOGGLE SWITCH	FP153-07
7	CURVED WASHER	TT171-08	25	CABLE TIE	AF030-01
8	NYLON LOCK NUT	XT098-02	26	BATTERY CABLE CLAMP	AT036-01
9	T/H BASE BLACK	AT004-11	27	HANDLE BOSS BUSHING	AT022-01
10	SCREW #8 X 1"	LF141-04	28	RETAINER CLAMP	AR036-02
11	COLUMN SEAL	AT079-01	29	8 X 1-3/8 SCREW	AR133-01
12	DEPTH ADJUSTMENT COLLAR	AR158-01	30	NOMENCLATURE DECAL	AT056-22
13	COLUMN 36"	FR049-11	31	BATTERY CABLE	XT328-06
	COLUMN 42"	FR049-12	32	GROMMET	GR019-01
	COLUMN 50"	FR049-13			
14	LOWER UNIT DECAL	AF060-07			
15	MONOFILAMENT WASHER	AR175-01			
16	PROP DRIVE PIN	BR102-02			
17	PROP/3 BLADE	AF124-11			
	PROP/2 BLADE	AF124-07			
18	PROP NUT	AR099-01			

LOWER UNIT BREAKDOWN

Model:  
**580V**

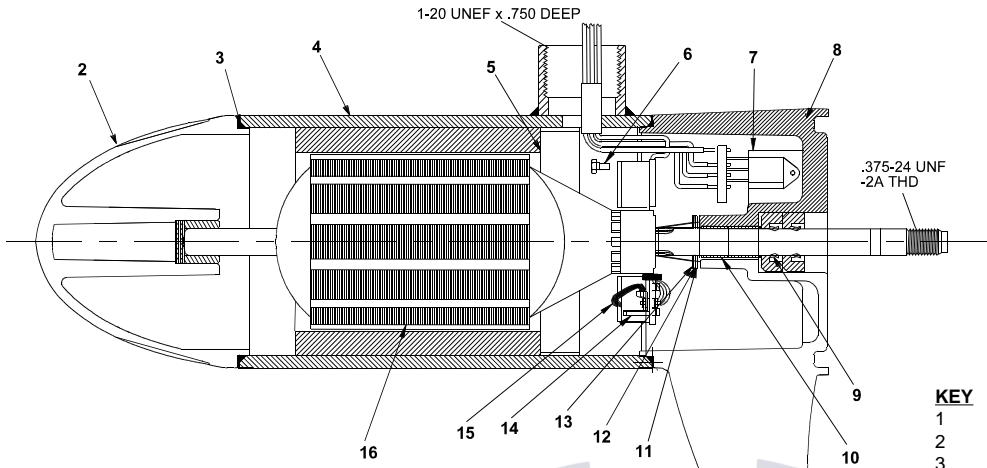

DIRECTION OF ROTATION IS COUNTER CLOCKWISE WHEN VIEWED FROM PROPELLER END WITH RED POSITIVE & BLACK NEGATIVE.

NOTE: TORQUE MOSFET BOLTS TO 35 TO 40 INCH LBS.

NOTE: TORQUE THRU BOLTS TO 40 TO 50 INCH LBS.

KEY	QTY	DESCRIPTION	PART NO.
1	X	MOTOR	TF397-01
2	1	NOSE CAP	XF3212-01
3	2	O RING SEAL	MR217-01
4	1	HOUSING ASY	AF3210-06
5	1	RETAINER	JF233-01
6	2	BRUSH CARD SCREW	MR228-01
7	1	DURA AMP MODULE	JF096-09
8	1	COMM CAP	XF3205-01
9	2	SHAFT SEAL	MR223-01
10	1	BEARING	MR206-01
11	1	NYLATRON WASHER	MR226-01
12	1	WASHER	MR227-01
13	1	E RING	MR219-02
14	2	BRUSH SPRINGS	XF214-01
15	1	BRUSH ASY LESS SPRING	XF3201-01
16	1	ARMATURE	TF3207-01
17	4	STATIC SEAL	MR222-01
18	4	THRU BOLT WASHER	MR216-02
19	2	DURA AMP SCREW	MR229-04
20	2	THRU BOLT	MR218-02

WIRING

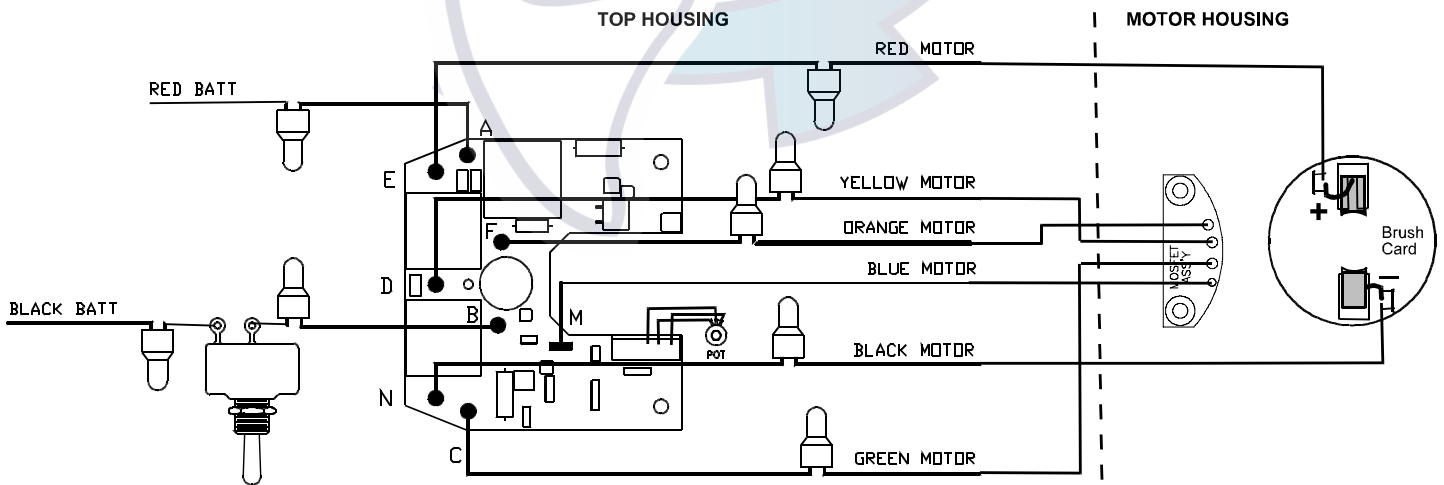

SUBJECT TO DAMAGE BY STATIC ELECTRICITY ASSEMBLE AT STATIC FREE WORK STATION!